

MAGNETBOREMASKINER OG KERNEBOR



MAGNETBOREMASKINE

MABASIC 35



MABasic 35 magnetboremaskine med 19 mm (3/4") Weldon holder. Modellen har kølemiddelbeholder for permanent indvendig smøring. Kontakter er placeret på toppen af huset for nem betjening.

Optagen effekt (Watt)	1.050
Volt	230
Omdrejningstal (min-1)	450
Vandring (mm)	160
Magnet størrelse i mm (BxLxH)	84 x 168 x 48
Kernebor kort 30 mm lang 55 mm	12-35 12-35
Tilslutning	19 mm Weldon (3/4")
Permanent indvendig smøring	✓
Vægt (kg)	12,0
Varenr.	MABasic35
Lager	✓

MAGNETBOREMASKINE

MABASIC 40



MABasic 40 har en 1.050 W motor. Den har en borekapacitet på 12-40 mm i enten korte serier (30 mm skæredybde) eller lange serier (55 mm skæredybde) kernebor. Fuldt bærbar med en vægt på kun 12 kg. Maskinen leveres med keyless Weldon tilslutning.

Optagen effekt (Watt)	1.050
Volt	230
Omdrejningstal (o/min)	450
Vandring (mm)	160
Kernebor kort 30 mm lang 55 mm	12-40 12-40
Max. boreddybde i stål (mm)	55
Tilslutning	19 mm Weldon (3/4")
Permanent indvendig smøring	✓
Vægt (kg)	12,0
Varenr.	MABasic 40
Lager	✓

MAGNETBOREMASKINE

MABASIC 50



MABasic 50 har en to-hastigheds 1.150 W motor. Den har en borekapacitet på 12-50 mm i enten korte serier (30 mm skæredybde) eller lange serier (55 mm skæredybde) kernebor. Fuldt bærbar med en vægt på kun 13 kg.

Optagen effekt (Watt)	1.150
Volt	230
Omdrejningstal (o/min)	Gear 1: 250 Gear 2: 450
Vandring (mm)	160
Kernebor kort 30 mm lang 55 mm	12-50 12-50
Max. boreddybde i stål (mm)	55
Spiralbor max. Ø (mm)	18
Tilslutning	MK2
Permanent indvendig smøring	✓
Vægt (kg)	13,0
Varenr.	MABasic 50
Lager	✓

MAGNETBOREMASKINE

MABASIC 400



Robust og pålidelig 1.050 W motor med høj hastighed. Motorsikkerhedsafbryderen og magnetkontakten er placeret i midten af bagsiden på et antirefleksdisplay. MABasic 400 kan således betjenes sikkert selv under arbejde over hovedet eller ved arbejde på en lodret overflade.

Optagen effekt (Watt)	1.050
Volt	230
Omdrejningstal (o/min)	430 760
Vandring (mm)	160
Magnet størrelse i mm (BxLxH)	84 x 160 x 41,5
Kernebor kort 30 mm lang 55 mm	12-35 12-35
Spiralbor (max. Ø mm)	op til 16
Max. boreddybde i stål (mm)	35
Tilslutning	19 mm Weldon (3/4")
Indvendig smøring	✓
Vægt (kg)	12,0
Varenr.	MABasic 400
Lager	✓

(Se teknisk tegning side 249)

MAGNETBOREMASKINE

MABASIC 450



(Se teknisk tegning side 249)

Med en motoreffekt på 1.150 W og en vægt på kun 13 kg er dette en bærbar og pålidelig arbejdshest på værkstedet og på samlebåndet. Boring af diametre op til 40/50 mm med en skæredybde på 55 mm.

Optagen effekt (Watt)	1.150
Volt	230
Omdrejningstal (o/min)	250 450
Vandring (mm)	160
Magnet størrelse i mm (BxLxH)	84 x 168 x 41,5
Kernebor kort 30 mm lang 55 mm	12-40 12-40
Spiralbor (max. Ø mm)	op til 18
Max. boreddybde i stål (mm)	30/55
Tilslutning	MK2, 19 mm Weldon (3/4")
Indvendig smøring	✓
Vægt (kg)	13,0
Varenr.	MABasic 450
Lager	✓

MAGNETBOREMASKINE

MABASIC 850



(Se teknisk tegning side 249)

MABasic 850 giver rigelig ydelse med en 1.800 W motor. Takket være 255 mm vandring kan større dele også bearbejdes med denne maskine. MABasic 850 er designet til kernebor med en diameter på op til 75 mm og længde op til 110 mm.

Optagen effekt (Watt)	1.800
Volt	230
Omdrejningstal (o/min)	Gear 1: 110 Gear 2: 175 Gear 3: 425 Gear 4: 385
Vandring (mm)	255
Magnet størrelse i mm (BxLxH)	110 x 220 x 54
Kernebor kort 30 mm lang 55 mm lang 75 mm ekstra lang 110 mm	12 - 75 2 - 75 18 - 60 20 - 60
Spiralbor (max. Ø mm)	31,75
Max. boreddybde i stål (mm)	110
Tilslutning	MK 3, 19 mm Weldon (3/4") MK 3, 32 mm Weldon (1 1/4")
Spindelkonus	MK 3
Indvendig smøring	✓
Vægt (kg)	24,0
Varenr.	MABasic 850
Lager	✓

MAGNETBOREMASKINE

MAB 100.1K



Med sine kun 9,9 kg er MAB 100 K magnetboremaskine letvægteren i BDS-serien. Let at håndtere og med lav totalhøjde. De indvendige ledninger sikrer en høj grad af sikkerhed under arbejdet. Udstyret med KEYLESS quick-change boresystem.

Optagen effekt (Watt)	800
Volt	230
Omdrejningstal (o/min)	450
Vandring (mm)	70
Magnet størrelse i mm (BxLxH)	80 x 160 x 41,5
Kernebor kort 30 mm lang 55 mm	12-30 12-30
Max. boreddybde i stål (mm)	30
Tilslutning	KEYLESS, 19 mm Weldon (3/4")
Permanent indvendig smøring	✓
Vægt (kg)	9,9
Varenr.	MAB 100.1K
Lager	✓

(Se teknisk tegning side 248)

MAGNETBOREMASKINE

MAB 155PRO



Idel til boring i ekstremt trange rum. Integreret LED Spot Light for mere synlighed og præcis boring. MAB155 er en handy og kompakt maskine til boring i trange rum. Den er nu udstyret med en kraftig motor.

Optagen effekt (Watt)	1.050
Volt	230
Omdrejningstal (o/min)	320
Vandring (mm)	39
Magnet størrelse i mm (BxLxH)	80 x 160 x 36,5
Kernebor kort 30 mm	12-35
Max. boreddybde i stål (mm)	30
Tilslutning	19 mm Weldon (3/4")
Permanent indvendig smøring	✓
Vægt (kg)	11,0
Varenr.	MAB 155PRO
Lager	✓

(Se teknisk tegning side 249)

MAGNETBOREMASKINE

MAB 455



Den kraftige MAB 455 er alt, hvad du behøver, mens du borer på et værksted. MAB 455 magnetbor er udstyret med MK2 holder, hvilket også gør det praktisk at bore med spiralbor op til 18 mm diameter og konisk skaft.

Optagen effekt (Watt)	1.150
Volt	230
Omdrejningstal (o/min)	250 450
Vandring (mm)	160
Magnet størrelse i mm (BxLxH)	84 x 168 x 41,5
Kernebor kort 30 mm lang 55 mm	12-40 12-40
Max. boreddybde i stål (mm)	30/55
Spiralbor max. Ø (mm)	18
Tilslutning	KEYLESS, 19 mm Weldon (3/4")
Spindelkonus	MK 2
Permanent indvendig smøring	✓
Vægt (kg)	13,0
Varenr.	MAB 455
Lager	✓

(Se teknisk tegning side 248)

MAGNETBOREMASKINE

MAB 485



Den kompakte allrounder. En bred vifte af mulige anvendelser og fremragende ydeevne gør MAB 485 til en af de mest populære maskiner blandt fagfolk til metalbearbejdning.

Optagen effekt (Watt)	1.150
Volt	230
Omdrejningstal (o/min)	50 - 250 100 - 450
Vandring (mm)	160
Magnet størrelse i mm (BxLxH)	84 x 168 x 41,5
Kernebor kort 30 mm lang 55 mm	12 - 40 12 - 40
Max. boreddybde i stål (mm)	30/55
Spiralbor max. Ø (mm)	18
Forsænker max. Ø (mm)	40
Rival max. Ø (mm)	18
Gevindskæring	M8 - M16
Tilslutning	KEYLESS, 19 mm Weldon (3/4")
Spindelkonus	MK 2
Permanent indvendig smøring	✓
Vægt (kg)	13,0
Varenr.	MAB 485
Lager	✓

(Se teknisk tegning side 248)

MAGNETBOREMASKINE

MAB 525



(Se teknisk tegning side 248)

Magnetboremaskine med to-trins oliebadsgearkasse. Ideel til service- og vedligeholdelsesafdeling takket være kun 16 kg vægt. Med MK3 morsekonusholder og borekapacitet op til Ø 50 mm. Vridningsstabilt design gennem gearkassehus i ét stykke med slæde.

Optagen effekt (Watt)	1.600
Volt	230
Omdrejningstal (o/min)	70-280 180-580
Vandring (mm)	160
Magnet størrelse i mm (BxLxH)	90 x 180 x 48
Kernebor kort 30 mm lang 55 mm	12 - 50 12 - 50
Max. boreddybde i stål (mm)	30/55
Spiralbor max. Ø (mm)	20
Forsænker max. Ø (mm)	50
Rival max. Ø (mm)	20
Gevindskæring	M20
Tilslutning	KEYLESS, 19 mm Weldon (3/4")
Spindelkonus	MK 3
Permanent indvendig smøring	✓
Vægt (kg)	16,0
Varenr.	MAB 525
Lager	✓

MAGNETBOREMASKINE

MAB 825



(Se teknisk tegning side 248)

Klassikeren blandt de store BDS magnetboremaskiner. Til kerneboring op til Ø 100 mm og 110 mm skæredybde. Gevind op til M30. Velegnet til spiralboring, oprømning og forsænkning. En MK3 magnetboremaskine.

Optagen effekt (Watt)	1.800
Volt	230
Omdrejningstal (o/min)	40-110/65-175/ 140-360/220-600
Vandring (mm)	255
Magnet størrelse i mm (BxLxH)	110 x 220 x 54
Kernebor kort: 30 mm / lang: 55 mm / lang: 75 mm ekstra lang: 110 mm	12 - 100/12 - 100/18 - 60 20 - 60
Max. boreddybde i stål (mm)	30/55 ⁽¹⁾ 110 ⁽²⁾
Spiralbor max. Ø (mm)	31,75
Forsænker max. Ø (mm)	50
Rival max. Ø (mm)	31,75
Gevindskæring	M30
Tilslutning	MK 3, 32 mm Weldon (1 1/4") KEYLESS, 19 mm Weldon (3/4")
Spindelkonus	MK 3
Permanent indvendig smøring	✓
Vægt (kg)	25,0
Varenr.	MAB 825
Lager	✓

MAGNETBOREMASKINE

MAB 825V / AUTOMATISK TILSPÆNDING



(Se teknisk tegning side 249)

Magnetboremaskine med maksimal ydeevne og fleksibilitet til stål-, anlægs- og maskinkonstruktion.

Optagen effekt (Watt)		1.800
Volt		230
Omdrejningstal (o/min)		40-110/65-175/ 140-360/220-600
Vandring (mm)		255
Magnet størrelse i mm (BxLxH)		110 x 220 x 54
Kernebor	(Automatisk tilspændning) kort: 30 mm / lang: 55 mm	12 - 60/12 - 60
Kernebor	(Manuel tilspændning) kort: 30 mm / lang: 55 mm	12 - 100/12 - 100
Max. boreddybde i stål mm		30/55
Spiralbor max. Ø mm	(Manuel tilspændning)	31,75
Spiralbor max. Ø mm	(Automatisk tilspændning)	26
Forsænker max. Ømm	(Manuel tilspændning)	50
Rival max. Ø mm	(Automatisk tilspændning)	31,75
Gevindskæring (max.)	(Manuel tilspændning)	M30
Tilslutning		MK 3, 32 mm Weldon (1 1/4") KEYLESS, 19 mm Weldon (3/4")
Spindelkonus		MK 3
Permanent indvendig smøring		✓
Vægt (kg)		34,0
Varenr.		MAB 825V
Lager		✓

MAGNETBOREMASKINE

MAB 845



(Se teknisk tegning side 248)

Klassikeren blandt de store BDS magnetboremaskiner. Til kerneboring op til Ø 100 mm og 110 mm skæredybde. Gevind op til M30. Velegnet til spiralboring, oprømning og forsænkning. En MK3 magnetboremaskine.

Optagen effekt (Watt)		1.800
Volt		230
Omdrejningstal (o/min)		40-110/65-175/ 140-360/220-600
Vandring (mm)		255
Magnet størrelse i mm (BxLxH)		110 x 220 x 54
Kernebor kort: 30 mm / lang: 55 mm / lang: 75 mm ekstra lang: 110 mm		12 - 100/12 - 100/18 - 60 20 - 60
Max. boreddybde i stål (mm)		30/55 ⁽¹⁾ 110 ⁽²⁾
Spiralbor max. Ø (mm)		31,75
Forsænker max. Ø (mm)		50
Rival max. Ø (mm)		31,75
Gevindskæring		M30
Tilslutning		MK 3, 32 mm Weldon (1 1/4") KEYLESS, 19 mm Weldon (3/4")
Spindelkonus		MK 3
Permanent indvendig smøring		✓
Vægt (kg)		25,0
Varenr.		MAB 845
Lager		✓

MAGNETBOREMASKINE

MAB 845V / AUTOMATISK TILSPÆNDING



(Se teknisk tegning side 249)

Med maksimal ydeevne og fleksibilitet til stål-, anlægs- og maskinkonstruktion.

Optagen effekt (Watt)		1.800
Volt		230
Omdrejningstal (o/min)		40-110/65-175/ 140-360/220-600
Vandring (mm)		255
Magnet størrelse i mm (BxLxH)		110 x 220 x 54
Kernebor	(Automatisk tilspændning) kort: 30 mm / lang: 55 mm	12 - 60/12 - 60
Kernebor	(Manuel tilspændning) kort: 30 mm / lang: 55 mm	12 - 100/12 - 100
Max. boreddybde i stål mm		30/55
Spiralbor max. Ø mm	(Manuel tilspændning)	31,75
Spiralbor max. Ø mm	(Automatisk tilspændning)	26
Forsænker max. Ø mm	(Manuel tilspændning)	50
Rival max. Ø mm	(Automatisk tilspændning)	31,75
Gevindskæring	(Manuel tilspændning)	M30
Tilslutning		MK 3, 32 mm Weldon (1 1/4") KEYLESS, 19 mm Weldon (3/4")
Spindelkonus		MK 3
Permanent indvendig smøring		✓
Vægt (kg)		34,0
Varenr.		MAB 845 V
Lager		÷

MAGNETBOREMASKINE

MAB 1300



(Se teknisk tegning side 248)

Overlegen ydeevne med enestående kraftoverskud. Udstyret med Servo Assist Power Feed, der fungerer som en servostyring af en bil, hvilket gør boringen ubesværet. 2.300 W motoreffekt, fire hastigheder og en komplet pakke af funktioner lader intet tilbage at ønske. MAB 1300 magnetboremaskinen går til grænsen for magnetisk kerneboret teknologi.

Optagen effekt (Watt)		2.300
Volt		230
Omdrejningstal (o/min)		30-80/50-120/ 130-350/210-550
Vandring (mm)		85/310
Magnet størrelse i mm (BxLxH)		120 x 360 x 67
Kernebor kort: 30 mm / lang: 55 mm / lang: 75 mm ekstra lang: 110 mm		12 - 130/12 - 130/18 - 120 20 - 120
Max. boreddybde i stål (mm)		30 55 110
Spiralbor max. Ø (mm)		45
Forsænker max. Ø (mm)		80
Rival max. Ø (mm)		50
Gevindskæring		M42
Tilslutning		32 mm Weldon (1 1/4")
Spindelkonus		MK4
Permanent indvendig smøring		✓
Vægt (kg)		51,0
Varenr.		MAB 1300
Lager		✓

MAGNETBOREMASKINE

MAB 1300V



Manuel eller automatisk tilspænding

(Se teknisk tegning side 249)

MAB 1300 V er i øjeblikket den mest kraftfulde magnetboremaskine med kontrollerbar automatisk tilspænding. Ideel til boring, oprømning og forsænkning.

Optagen effekt (Watt)	2.300
Volt	230
Omdrejningstal (o/min)	30-80/50-120/ 130-350/210-550
Vandring (mm)	310
Magnet størrelse i mm (BxLxH)	120 X 360 X 67 mm
Kernebor (Automatisk tilspænding) kort: 30 mm / lang: 55 mm / ekstra lag: 110 mm	12-60/12-60/20-60
Kernebor (Manuel tilspænding) kort: 30 mm / lang: 55 mm / ekstra lag: 110 mm	12-130/12-100/20-100
Spiralbor max. Ø mm (Manuel tilspænding)	45
Spiralbor max. Ø mm (Automatisk tilspænding)	32
Forsænker max. Ø mm (Manuel tilspænding)	80
Rival max Ø mm (Automatisk tilspænding)	50
Gevindskæring (Manuel tilspænding)	M42
Tilslutning	19 mm og 32 mm Weldon (1 1/4")
Spindelkonus	MK4
Permanent indvendig smøring	✓
Vægt (kg)	51,0
Varenr.	MAB 1300 V
Lager	✓

MAGNETBOREMASKINE

AUTOMAB 350 / AUTOMATISK TILSPÆNDING



AutoMAB 350 er nem at betjene og kan bore huller med en diameter på 35 mm i en skæredybde på 55 mm. Automatisk boring, automatisk reversering og automatisk slukning.

Optagen effekt (Watt)	1.050
Volt	230
Omdrejningstal (o/min)	360
Vandring (mm)	150
Magnet størrelse i mm (BxLxH)	84 x 168 x 48
Kernebor kort: 30 mm / lang: 55 mm	12-35 / 12-35
Tilslutning	19 mm Weldon (3/4")
Permanent indvendig smøring	✓
Vægt (kg)	15,0
Varenr.	AutoMAB 350
Lager	✓

(Se teknisk tegning side 249)

MAGNETBOREMASKINE AUTOMAB 450 / AUTOMATISK TILSPÆNDING



AutoMAB 450 er udstyret med MK2 spindelkonus. AutoMAB 450 kan bore huller med en diameter på 45 mm i en skæredybde på 55 mm.

Optagen effekt (Watt)	1.150
Volt	230
Omdrejningstal (o/min)	250/450
Vandring (mm)	150
Magnet størrelse i mm (BxLxH)	84 x 168 x 48
Kernebor kort: 30 mm / lang: 55 mm	12-45 / 12-45
Tilslutning	MK2 ,19 mm Weldon (3/4")
Permanent indvendig smøring	✓
Vægt (kg)	16,0
Varenr.	AutoMAB 450
Lager	✓

(Se teknisk tegning side 249)

MAGNETBOREMASKINE AIRMAB 5000PRO



Boring ved hjælp af trykluftmotor og permanent magnet. Udstyret med en speciel innovative rørmagneter, som er ideel til rør. En ideel pneumatisk boremaskine til olie- og gasindustrien og til brandfarlige opgaver.

Optagen effekt (Watt)	830
Omdrejningstal (o/min)	min. 290 max. 575
Vandring (mm)	160
Nominelt drejningsmoment (Nm)	27
Luftforbrug (l/min)	1.000
Magnet størrelse i mm (BxLxH)	191 x 266 x 88
Kernebor kort: 30 mm / lang: 55 mm	12-35 / 12-35
Max. boreddybde i stål (mm)	55
Spiralbor max. Ø (mm)	23
Tilslutning	KEYLESS, 19 mm Weldon (3/4")
Spindelkonus	MK2
Permanent indvendig smøring	✓
Vægt (kg)	17,5
Varenr.	AirMAB 5000PRO
Lager	÷

(Se teknisk tegning side 249)

MAGNETBOREMASKINE

PIPEMAB 200



Stærk magnetisk kraft op til max. 1.020 kg. Det patenterede magnetiske spændesystem tilpasser sig automatisk til rørdiameteren. Drejningsarrangementet af de permanente magneter gør det muligt at dreje, så det passer til ethvert rør, der er Ø 85 mm (3") diameter eller større.

Optagen effekt (Watt)	1.050
Volt	230
Omdrejningstal (min-1)	450
Vandring (mm)	160
Magnet størrelse i mm (BxLxH)	191 x 266 x 88
Boreddybde max. (mm)	40
Kernebor længde (mm)	32
Tilslutning	19 mm Weldon
Permanent indvendig smøring	✓
Vægt (kg)	16,0
Varenr.	PIPEMAB200
Lager	✓

(Se teknisk tegning side 250)



MAGNETBOREMASKINE

PIPEMAB 525



Stærk magnetisk kraft op til max. 1.020 kg. Det patenterede magnetiske spændesystem tilpasser sig automatisk til rørdiameteren. Drejningsarrangementet af de permanente magneter gør det muligt at dreje, så det passer til ethvert rør, der er Ø 85 mm (3") diameter eller større.

Optagen effekt (Watt)	1.600
Volt	230
Omdrejningstal (min-1)	Gear 1: 70-280 Gear 2: 180-580
Vandring (mm)	160
Magnet størrelse i mm (BxLxH)	191 x 266 x 88
Boreddybde max. (mm)	40
Kernebor længde (mm)	50
Spiralbor (mm)	20
Gevind max.	M20
Tilslutning	MK3
Permanent indvendig smøring	✓
Vægt (kg)	19,5
Varenr.	PIPEMAB525
Lager	✓

(Se teknisk tegning side 250)



TOGSKINNE BOREMASKINE RAILMAB 915



Magnetboremaskine med 1.600 Watt motor og 2-trins oliebad gearkasse.

Optagen effekt (Watt)	1.600
Volt	230
Omdrejningstal (o/min)	70-280 180-580
Vandring (mm)	160
Kernebor Ø (mm)	17-36
Tilslutning	KEYLESS, 19 mm Weldon (3/4")
Spindelkonus	MK3
Permanent indvendig smøring	✓
Køling	Kølemiddel
Vægt (kg)	17,0
Varenr.	RailMAB 915
Lager	÷

(Se teknisk tegning side 250)

TOGSKINNE BOREMASKINE RAILMAB 965



Letvægtsskinneboremaskine. Kun 21,5 kg i vægt og kan håndteres og betjenes af en enkelt operatør.

Motor	Benzin
Afgiven effekt (KW)	1,5
Omdrejningstal (o/min)	Minium 110 Maxium 280
Motor (ccm)	49,4
Benzintank (L)	0,5
Vandring (mm)	40
Drejningsmoment (Nm)	3,04
Kernebor Ø (mm)	17 - 36
Kernebor kort (mm)	30
Tilslutning	Direkte 19 mm Weldon (3/4")
Vægt (kg)	21,5
Permanent indvendig smøring	✓
Køling	Kølemiddel
Varenr.	RailMAB 965
Lager	÷

(Se teknisk tegning side 250)

TILBEHØR

ZMC 200



Bordplade mål (mm)	370 x 240 x 88
Magnet størrelse i mm (H x B)	90 x 180
Materiale	Stål/aluminium
Vægt (kg)	3,5
Varenr.	ZMC 200
Lager	✓

TILBEHØR

POW 100/200

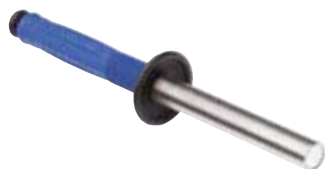

Beskrivelse	Varenr.	Lager
Power Worker (spån opsamler)	POW 100	✓
Power Cleaner (spån renser)	POW 200	✓

KERNEBORSÆT

KBK 002/HKK 002



Beskrivelse	Varenr.	Lager
KBK 013-014-017-018-021-022 x 1 Centerstift ZAK 075 x 1 Skæredybde 30 mm	KBK 002	✓
HKK HM 013-014-017-018-021- 022 x 1 Centerstift ZAK 075 x 1 Skæredybde 30 mm HKK HM 005	HKK 002	✓

HULSAV HM

PL 52000



Hårdmetal hulsav til rustfri stål, stål, støbejern og aluminium. Med TIN centrerbør og udstøderfjeder. Max 5 mm godstykkelse. 16 mm kopdybde.



Ø/mm	Ø skaft mm	Varenr.	Lager
15,0	10	PL52015	✓
16,0	10	PL52016	✓
17,0	10	PL52017	✓
18,0	10	PL52018	✓
19,0	10	PL52019	✓
20,0	10	PL52020	✓
21,0	10	PL52021	✓
22,0	10	PL52022	✓
23,0	10	PL52023	✓
24,0	10	PL52024	✓
25,0	10	PL52025	✓
26,0	10	PL52026	✓
27,0	10	PL52027	✓
28,0	10	PL52028	✓
29,0	10	PL52029	✓
30,0	10	PL52030	✓
31,0	10	PL52031	✓
32,0	10	PL52032	✓
33,0	10	PL52033	✓
34,0	10	PL52034	✓
35,0	10	PL52035	✓
36,0	10	PL52036	✓
37,0	10	PL52037	✓
38,0	10	PL52038	✓
39,0	10	PL52039	✓
40,0	10	PL52040	✓
41,0	10	PL52041	✓
42,0	10	PL52042	✓

Ø/mm	Ø skaft mm	Varenr.	Lager
43,0	13	PL52043	✓
44,0	13	PL52044	✓
45,0	13	PL52045	✓
46,0	13	PL52046	✓
47,0	13	PL52047	✓
48,0	13	PL52048	✓
49,0	13	PL52049	✓
50,0	13	PL52050	✓
51,0	13	PL52051	✓
52,0	13	PL52052	✓
53,0	13	PL52053	✓
54,0	13	PL52054	✓
55,0	13	PL52055	✓
56,0	13	PL52056	✓
57,0	13	PL52057	✓
58,0	13	PL52058	✓
59,0	13	PL52059	✓
60,0	13	PL52060	✓
65,0	13	PL52065	✓
68,0	13	PL52068	✓
70,0	13	PL52070	✓
75,0	13	PL52075	✓
80,0	13	PL52080	✓
85,0	13	PL52085	✓
90,0	13	PL52090	✓
95,0	13	PL52095	✓
100,0	13	PL52100	✓

CENTREBOR/FJEDER



PD59557

Centrerbor og fjeder til hårdmetal hulsav.

Pakke enhed: 1 stk.



SP59552

Ø/mm	Længde mm	Varenr.	Lager
5,9	58	PD59557	✓
-	-	SP59552	✓

HM HULSAVSÆT METAL



PL521630

Hårdmetal hulsav sæt til rustfri stål, stål, støbejern og aluminium.

- Med TIN centrerbor og udstøderfjeder
- Max 5 mm godstykkelse
- Kopdybde: 16 mm



PL521650

Indhold	Indhold	Varenr.	Lager
16/18/20/22/25/30 mm	6 dele	PL521630	✓
16/18/20/22/25/30/35/40 /45/50 mm	10 dele	PL521650	✓

SPIRALBOR SPS

HSS-STANDARD



Spiralbor HSS 6 - 14 mm med 19 mm Weldon skaft.
Spiral længde 35 mm

Ø/mm	Varenr.	Lager
6,0	SPS 060	✓
6,8	SPS 068	✓
8,0	SPS 080	✓
8,5	SPS 085	✓
10,0	SPS 100	✓

Ø/mm	Varenr.	Lager
10,2	SPS 102	✓
12,0	SPS 120	✓
13,0	SPS 130	✓
14,0	SPS 140	✓



KBK Kernebor HSS 12 - 60 mm med 19 mm Weldon skaft.
Skæredybde 30 mm.

Ø/mm	Varenr.	Lager
12	KBK 012	✓
13	KBK 013	✓
14	KBK 014	✓
15	KBK 015	✓
16	KBK 016	✓
17	KBK 017	✓
17,5	KBK 175	✓
18	KBK 018	✓
19	KBK 019	✓
19,5	KBK 195	✓
20	KBK 020	✓
21	KBK 021	✓
22	KBK 022	✓
23	KBK 023	✓
24	KBK 024	✓
25	KBK 025	✓
26	KBK 026	✓
27	KBK 027	✓
28	KBK 028	✓
29	KBK 029	✓
30	KBK 030	✓
31	KBK 031	✓
32	KBK 032	✓
33	KBK 033	✓
34	KBK 034	✓
35	KBK 035	✓

Ø/mm	Varenr.	Lager
36	KBK 036	✓
37	KBK 037	✓
38	KBK 038	✓
39	KBK 039	✓
40	KBK 040	✓
41	KBK 041	✓
42	KBK 042	✓
43	KBK 043	✓
44	KBK 044	✓
45	KBK 045	✓
46	KBK 046	✓
47	KBK 047	✓
48	KBK 048	✓
49	KBK 049	✓
50	KBK 050	✓
51	KBK 051	✓
52	KBK 052	✓
53	KBK 053	✓
54	KBK 054	✓
55	KBK 055	✓
56	KBK 056	✓
57	KBK 057	✓
58	KBK 058	✓
59	KBK 059	✓
60	KBK 060	✓

CENTRERSTIFT

ZAK 075



Størrelse	Varenr.	Lager
Ø 12 - 60 mm	ZAK 075	✓



KBK Kernebor HSS-E 61 - 130 mm med 32 mm Weldon skaft.
Skæredybde 30 mm.

Ø/mm	Varenr.	Lager
61	KBK-CO 061	✓
62	KBK-CO 062	✓
63	KBK-CO 063	✓
64	KBK-CO 064	✓
65	KBK-CO 065	✓
66	KBK-CO 066	✓
67	KBK-CO 067	✓
68	KBK-CO 068	✓
69	KBK-CO 069	✓
70	KBK-CO 070	✓
71	KBK-CO 071	✓
72	KBK-CO 072	✓
73	KBK-CO 073	✓
74	KBK-CO 074	✓
75	KBK-CO 075	✓
76	KBK-CO 076	✓
77	KBK-CO 077	✓
78	KBK-CO 078	✓
79	KBK-CO 079	✓
80	KBK-CO 080	✓
81	KBK-CO 081	✓
82	KBK-CO 082	✓

Ø/mm	Varenr.	Lager
83	KBK-CO 083	÷
84	KBK-CO 084	÷
85	KBK-CO 085	✓
86	KBK-CO 086	÷
87	KBK-CO 087	÷
88	KBK-CO 088	÷
89	KBK-CO 089	÷
90	KBK-CO 090	✓
91	KBK-CO 091	÷
92	KBK-CO 092	÷
93	KBK-CO 093	÷
94	KBK-CO 094	÷
95	KBK-CO 095	✓
96	KBK-CO 096	÷
97	KBK-CO 097	÷
98	KBK-CO 098	✓
99	KBK-CO 099	÷
100	KBK-CO 100	✓
110	KBK-CO 110	✓
120	KBK-CO 120	✓
130	KBK-CO 130	✓

CENTRERSTIFT
ZAK 090



Størrelse	Varenr.	Lager
Ø 61 - 130 mm	ZAK 090	✓



HSS-Co 8-F Kernebor 12 - 60 mm med FEIN QuickIN skaft.
Skæredybde 35 mm.

Ø/mm	Varenr.	Lager
12	KBK-F 012	÷
13	KBK-F 013	÷
14	KBK-F 014	÷
15	KBK-F 015	÷
16	KBK-F 016	÷
17	KBK-F 017	÷
18	KBK-F 018	÷
19	KBK-F 019	÷
20	KBK-F 020	÷
21	KBK-F 021	÷
22	KBK-F 022	÷
23	KBK-F 023	÷
24	KBK-F 024	÷
25	KBK-F 025	÷
26	KBK-F 026	÷
27	KBK-F 027	÷
28	KBK-F 028	÷
29	KBK-F 029	÷
30	KBK-F 030	÷
31	KBK-F 031	÷
32	KBK-F 032	÷
33	KBK-F 033	÷
34	KBK-F 034	÷
35	KBK-F 035	÷
36	KBK-F 036	÷

Ø/mm	Varenr.	Lager
37	KBK-F 037	÷
38	KBK-F 038	÷
39	KBK-F 039	÷
40	KBK-F 040	÷
41	KBK-F 041	÷
42	KBK-F 042	÷
43	KBK-F 043	÷
44	KBK-F 044	÷
45	KBK-F 045	÷
46	KBK-F 046	÷
47	KBK-F 047	÷
48	KBK-F 048	÷
49	KBK-F 049	÷
50	KBK-F 050	÷
51	KBK-F 051	÷
52	KBK-F 052	÷
53	KBK-F 053	÷
54	KBK-F 054	÷
55	KBK-F 055	÷
56	KBK-F 056	÷
57	KBK-F 057	÷
58	KBK-F 058	÷
59	KBK-F 059	÷
60	KBK-F 060	÷

CENTRERSTIFT
ZAK 075



Størrelse	Varenr.	Lager
Ø 12 - 60 mm	ZAK 075	✓



KBL Kernebor HSS 12 - 60 mm med 19 mm Weldon skaft.
Skæredybde 55 mm.

Ø/mm	Varenr.	Lager
12	KBL 012	✓
13	KBL 013	✓
14	KBL 014	✓
15	KBL 015	✓
16	KBL 016	✓
17	KBL 017	✓
17,5	KBL 175	✓
18	KBL 018	✓
19	KBL 019	✓
19,5	KBL 195	✓
20	KBL 020	✓
21	KBL 021	✓
22	KBL 022	✓
23	KBL 023	✓
24	KBL 024	✓
25	KBL 025	✓
26	KBL 026	✓
27	KBL 027	✓
28	KBL 028	✓
29	KBL 029	✓
30	KBL 030	✓
31	KBL 031	✓
32	KBL 032	✓
33	KBL 033	✓
34	KBL 034	✓
35	KBL 035	✓

Ø/mm	Varenr.	Lager
36	KBL 036	✓
37	KBL 037	✓
38	KBL 038	✓
39	KBL 039	✓
40	KBL 040	✓
41	KBL 041	✓
42	KBL 042	✓
43	KBL 043	✓
44	KBL 044	✓
45	KBL 045	✓
46	KBL 046	✓
47	KBL 047	✓
48	KBL 048	✓
49	KBL 049	✓
50	KBL 050	✓
51	KBL 051	✓
52	KBL 052	✓
53	KBL 053	✓
54	KBL 054	✓
55	KBL 055	✓
56	KBL 056	✓
57	KBL 057	✓
58	KBL 058	✓
59	KBL 059	✓
60	KBL 060	✓

CENTRERSTIFT

ZAK 100



Størrelse	Varenr.	Lager
Ø 12 - 60 mm	ZAK 100	✓



KBL Kernebor HSS-E 61 - 100 mm med 32 mm Weldon skaft.
Skæredybde 55 mm.

Ø/mm	Varenr.	Lager
61	KBL-CO 061	÷
62	KBL-CO 062	÷
63	KBL-CO 063	÷
64	KBL-CO 064	÷
65	KBL-CO 065	✓
66	KBL-CO 066	÷
67	KBL-CO 067	÷
68	KBL-CO 068	÷
69	KBL-CO 069	÷
70	KBL-CO 070	✓
71	KBL-CO 071	÷
72	KBL-CO 072	÷
73	KBL-CO 073	÷
74	KBL-CO 074	÷
75	KBL-CO 075	✓
76	KBL-CO 076	✓
77	KBL-CO 077	÷
78	KBL-CO 078	÷
79	KBL-CO 079	÷
80	KBL-CO 080	✓

Ø/mm	Varenr.	Lager
81	KBL-CO 081	÷
82	KBL-CO 082	÷
83	KBL-CO 083	÷
84	KBL-CO 084	÷
85	KBL-CO 085	✓
86	KBL-CO 086	÷
87	KBL-CO 087	÷
88	KBL-CO 088	÷
89	KBL-CO 089	÷
90	KBL-CO 090	✓
91	KBL-CO 091	÷
92	KBL-CO 092	÷
93	KBL-CO 093	÷
94	KBL-CO 094	÷
95	KBL-CO 095	✓
96	KBL-CO 096	÷
97	KBL-CO 097	÷
98	KBL-CO 098	÷
99	KBL-CO 099	÷
100	KBL-CO 100	✓

CENTRERSTIFT
ZAK 120



Størrelse	Varenr.	Lager
Ø 61 - 130 mm	ZAK 120	✓

KERNEBOR KEL

EKSTRA LANG**HSS-STANDARD**

KEL Kerkebor HSS Ekstra lang (110 mm) 20 - 50 mm med 19 mm Weldon skaft. Skæredybde 110 mm.

Ø/mm	Varenr.	Lager
20	KEL 020	✓
21	KEL 021	✓
22	KEL 022	✓
23	KEL 023	✓
24	KEL 024	✓
25	KEL 025	✓
26	KEL 026	✓
27	KEL 027	✓
28	KEL 028	✓
29	KEL 029	✓
30	KEL 030	✓
31	KEL 031	✓
32	KEL 032	✓
33	KEL 033	✓
34	KEL 034	✓
35	KEL 035	✓

Ø/mm	Varenr.	Lager
36	KEL 036	✓
37	KEL 037	✓
38	KEL 038	✓
39	KEL 039	✓
40	KEL 040	✓
41	KEL 041	÷
42	KEL 042	✓
43	KEL 043	÷
44	KEL 044	✓
45	KEL 045	✓
46	KEL 046	÷
47	KEL 047	÷
48	KEL 048	÷
49	KEL 049	÷
50	KEL 050	✓

CENTRERSTIFT ZAK 275



Størrelse	Varenr.	Lager
Ø 20 - 50 mm	ZAK 275	✓



HKKN kernebor HM 12 - 60 mm med 19 mm med combi skaft (Weldon og Nitto).
Skæredybde 30 mm.

Ø/mm	Varenr.	Lager
12	HKKN 012	✓
13	HKKN 013	✓
14	HKKN 014	✓
15	HKKN 015	✓
16	HKKN 016	✓
17	HKKN 017	✓
18	HKKN 018	✓
19	HKKN 019	✓
20	HKKN 020	✓
21	HKKN 021	✓
22	HKKN 022	✓
23	HKKN 023	✓
24	HKKN 024	✓
25	HKKN 025	✓
26	HKKN 026	✓
27	HKKN 027	✓
28	HKKN 028	✓
29	HKKN 029	✓
30	HKKN 030	✓
31	HKKN 031	✓
32	HKKN 032	✓
33	HKKN 033	✓
34	HKKN 034	✓
35	HKKN 035	✓
36	HKKN 036	✓

Ø/mm	Varenr.	Lager
37	HKKN 037	✓
38	HKKN 038	✓
39	HKKN 039	✓
40	HKKN 040	✓
41	HKKN 041	✓
42	HKKN 042	✓
43	HKKN 043	✓
44	HKKN 044	✓
45	HKKN 045	✓
46	HKKN 046	✓
47	HKKN 047	✓
48	HKKN 048	✓
49	HKKN 049	✓
50	HKKN 050	✓
51	HKKN 051	✓
52	HKKN 052	✓
53	HKKN 053	✓
54	HKKN 054	✓
55	HKKN 055	✓
56	HKKN 056	✓
57	HKKN 057	÷
58	HKKN 058	÷
59	HKKN 059	÷
60	HKKN 060	✓

CENTRERSTIFT

ZAK 075



Størrelse	Varenr.	Lager
Ø 12 - 60 mm	ZAK 075	✓



HKK kernebor HM 61 - 150 mm med 32 mm med Weldon skaft.
Skæredybde 30 mm.

Ø/mm	Varenr.	Lager
61	HKK 061	÷
62	HKK 062	÷
63	HKK 063	÷
64	HKK 064	÷
65	HKK 065	✓
66	HKK 066	÷
67	HKK 067	÷
68	HKK 068	÷
69	HKK 069	÷
70	HKK 070	✓
71	HKK 071	÷
72	HKK 072	÷
73	HKK 073	÷
74	HKK 074	÷
75	HKK 075	✓
76	HKK 076	÷
77	HKK 077	÷
78	HKK 078	÷
79	HKK 079	÷
80	HKK 080	✓
81	HKK 081	÷
82	HKK 082	÷
83	HKK 083	÷
84	HKK 084	÷
85	HKK 085	✓

Ø/mm	Varenr.	Lager
86	HKK 086	÷
87	HKK 087	÷
88	HKK 088	÷
89	HKK 089	÷
90	HKK 090	✓
91	HKK 091	÷
92	HKK 092	÷
93	HKK 093	÷
94	HKK 094	÷
95	HKK 095	✓
96	HKK 096	÷
97	HKK 097	÷
98	HKK 098	÷
99	HKK 099	÷
100	HKK 100	✓
105	HKK 105	÷
110	HKK 110	✓
115	HKK 115	÷
120	HKK 120	✓
125	HKK 125	÷
130	HKK 130	✓
135	HKK 135	÷
140	HKK 140	÷
145	HKK 145	÷
150	HKK 150	÷

CENTRERSTIFT

ZAK 090



Størrelse	Varenr.	Lager
Ø 61 - 150 mm	ZAK 090	✓

KERNEBOR

HKLN

LANG**HM STANDARD**

HKLN HM Kernebor 12 - 60 mm med 19 mm Combi skaft (Weldon og Nitto).
Skæredybde 55 mm.

Ø/mm	Varenr.	Lager
12	HKLN 012	✓
13	HKLN 013	✓
14	HKLN 014	✓
15	HKLN 015	✓
16	HKLN 016	✓
17	HKLN 017	✓
18	HKLN 018	✓
19	HKLN 019	✓
20	HKLN 020	✓
21	HKLN 021	✓
22	HKLN 022	✓
23	HKLN 023	✓
24	HKLN 024	✓
25	HKLN 025	✓
26	HKLN 026	✓
27	HKLN 027	✓
28	HKLN 028	✓
29	HKLN 029	✓
30	HKLN 030	✓
31	HKLN 031	✓
32	HKLN 032	✓
33	HKLN 033	✓
34	HKLN 034	✓
35	HKLN 035	✓
36	HKLN 036	✓

Ø/mm	Varenr.	Lager
37	HKLN 037	✓
38	HKLN 038	✓
39	HKLN 039	✓
40	HKLN 040	✓
41	HKLN 041	✓
42	HKLN 042	✓
43	HKLN 043	✓
44	HKLN 044	✓
45	HKLN 045	✓
46	HKLN 046	✓
47	HKLN 047	✓
48	HKLN 048	✓
49	HKLN 049	✓
50	HKLN 050	✓
51	HKLN 051	✓
52	HKLN 052	✓
53	HKLN 053	✓
54	HKLN 054	✓
55	HKLN 055	✓
56	HKLN 056	✓
57	HKLN 057	✓
58	HKLN 058	✓
59	HKLN 059	✓
60	HKLN 060	✓

CENTRERSTIFT

ZAK 100



Størrelse	Varenr.	Lager
Ø 14 - 60 mm	ZAK 100	✓

KERNEBOR

HKL

LANG

HM STANDARD



HKL HM Kernebor 61 - 100 mm med 32 mm Weldon skaft (1 1/4").
Skæredybde 55 mm.

Ø/mm	Varenr.	Lager
61	HKL 061	÷
62	HKL 062	÷
63	HKL 063	÷
64	HKL 064	÷
65	HKL 065	✓
66	HKL 066	÷
67	HKL 067	÷
68	HKL 068	÷
69	HKL 069	÷
70	HKL 070	✓
71	HKL 071	÷
72	HKL 072	÷
73	HKL 073	÷
74	HKL 074	÷
75	HKL 075	✓
76	HKL 076	÷
77	HKL 077	÷
78	HKL 078	÷
79	HKL 079	÷
80	HKL 080	✓

Ø/mm	Varenr.	Lager
81	HKL 081	÷
82	HKL 082	÷
83	HKL 083	÷
84	HKL 084	÷
85	HKL 085	✓
86	HKL 086	÷
87	HKL 087	÷
88	HKL 088	÷
89	HKL 089	÷
90	HKL 090	✓
91	HKL 091	÷
92	HKL 092	÷
93	HKL 093	÷
94	HKL 094	÷
95	HKL 095	✓
96	HKL 096	÷
97	HKL 097	÷
98	HKL 098	÷
99	HKL 099	÷
100	HKL 100	✓

CENTRERSTIFT

ZAK 120



Størrelse	Varenr.	Lager
Ø 61 - 100 mm	ZAK 120	✓



HKX-L HM Kernebor 18 - 60 mm med 19 mm Weldon skaft (3/4").
 HKX-L HM Kernebor 61 - 120 mm med 32 mm Weldon skaft (1 1/4").
 Skæredybde 75 mm.

Ø/mm	Varenr.	Lager
18	HKX-L 018	✓
19	HKX-L 019	✓
20	HKX-L 020	✓
21	HKX-L 021	✓
22	HKX-L 022	✓
23	HKX-L 023	✓
24	HKX-L 024	✓
25	HKX-L 025	✓
26	HKX-L 026	✓
27	HKX-L 027	✓
28	HKX-L 028	✓
29	HKX-L 029	✓
30	HKX-L 030	✓
31	HKX-L 031	✓
32	HKX-L 032	✓
33	HKX-L 033	✓
34	HKX-L 034	✓
35	HKX-L 035	✓
36	HKX-L 036	✓
37	HKX-L 037	✓
38	HKX-L 038	✓
39	HKX-L 039	✓
40	HKX-L 040	✓
41	HKX-L 041	✓
42	HKX-L 042	✓
43	HKX-L 043	✓

Ø/mm	Varenr.	Lager
44	HKX-L 044	✓
45	HKX-L 045	✓
46	HKX-L 046	✓
47	HKX-L 047	✓
48	HKX-L 048	✓
49	HKX-L 049	✓
50	HKX-L 050	✓
51	HKX-L 051	✓
52	HKX-L 052	✓
53	HKX-L 053	÷
54	HKX-L 054	÷
55	HKX-L 055	✓
56	HKX-L 056	÷
57	HKX-L 057	÷
58	HKX-L 058	÷
59	HKX-L 059	÷
60	HKX-L 060	✓
65	HKX-L 065	✓
70	HKX-L 070	✓
75	HKX-L 075	✓
80	HKX-L 080	✓
90	HKX-L 090	✓
100	HKX-L 100	✓
110	HKX-L 110	÷
120	HKX-L 120	÷

CENTRERSTIFT

ZAK 225/245



Størrelse	Varenr.	Lager
Ø 18 - 60 mm	ZAK 225	✓
Ø 61 - 120 mm	ZAK 245	✓

KERNEBOR

HKE-L

EKSTRA LANG**HM STANDARD**

HKE-L HM Kernebor 20 - 60 mm med 19 mm Weldon skaft (3/4").
HKE-L HM Kernebor 61 - 120 mm med 32 mm Weldon skaft (1 1/4").
Skæredybde 110 mm.

Ø/mm	Varenr.	Lager
18	HKE-L 018	✓
20	HKE-L 020	✓
21	HKE-L 021	✓
22	HKE-L 022	✓
23	HKE-L 023	✓
24	HKE-L 024	✓
25	HKE-L 025	✓
26	HKE-L 026	✓
27	HKE-L 027	✓
28	HKE-L 028	✓
29	HKE-L 029	✓
30	HKE-L 030	✓
31	HKE-L 031	✓
32	HKE-L 032	✓
33	HKE-L 033	✓
34	HKE-L 034	✓
35	HKE-L 035	✓
36	HKE-L 036	✓
37	HKE-L 037	✓
38	HKE-L 038	✓
39	HKE-L 039	✓
40	HKE-L 040	✓
41	HKE-L 041	÷
42	HKE-L 042	✓
43	HKE-L 043	÷

Ø/mm	Varenr.	Lager
44	HKE-L 044	✓
45	HKE-L 045	✓
46	HKE-L 046	÷
47	HKE-L 047	÷
48	HKE-L 048	÷
49	HKE-L 049	÷
50	HKE-L 050	✓
51	HKE-L 051	÷
52	HKE-L 052	÷
53	HKE-L 053	÷
54	HKE-L 054	÷
55	HKE-L 055	✓
56	HKE-L 056	÷
57	HKE-L 057	÷
58	HKE-L 058	÷
59	HKE-L 059	÷
60	HKE-L 060	✓
65	HKE-L 065	✓
70	HKE-L 070	✓
75	HKE-L 075	✓
80	HKE-L 080	✓
90	HKE-L 090	✓
100	HKE-L 100	✓
110	HKE-L 110	÷
120	HKE-L 120	÷

CENTRERSTIFT

ZAK 275



Størrelse	Varenr.	Lager
Ø 20 - 120 mm	ZAK 275	✓



HKK-F HM Kernebor 14 - 60 mm med FEIN QuickIN skaft.
Skæredybde 35 mm.

Ø/mm	Varenr.	Lager
14	HKK-F 014	÷
15	HKK-F 015	÷
16	HKK-F 016	÷
17	HKK-F 017	÷
18	HKK-F 018	÷
19	HKK-F 019	÷
20	HKK-F 020	÷
21	HKK-F 021	÷
22	HKK-F 022	÷
23	HKK-F 023	÷
24	HKK-F 024	÷
25	HKK-F 025	÷
26	HKK-F 026	÷
27	HKK-F 027	÷
28	HKK-F 028	÷
29	HKK-F 029	÷
30	HKK-F 030	÷
31	HKK-F 031	÷
32	HKK-F 032	÷
33	HKK-F 033	÷
34	HKK-F 034	÷
35	HKK-F 035	÷
36	HKK-F 036	÷
37	HKK-F 037	÷

Ø/mm	Varenr.	Lager
38	HKK-F 038	÷
39	HKK-F 039	÷
40	HKK-F 040	÷
41	HKK-F 041	÷
42	HKK-F 042	÷
43	HKK-F 043	÷
44	HKK-F 044	÷
45	HKK-F 045	÷
46	HKK-F 046	÷
47	HKK-F 047	÷
48	HKK-F 048	÷
49	HKK-F 049	÷
50	HKK-F 050	÷
51	HKK-F 051	÷
52	HKK-F 052	÷
53	HKK-F 053	÷
54	HKK-F 054	÷
55	HKK-F 055	÷
56	HKK-F 056	÷
57	HKK-F 057	÷
58	HKK-F 058	÷
59	HKK-F 059	÷
60	HKK-F 060	÷

CENTRERSTIFT
ZAK 096



Størrelse	Varenr.	Lager
Ø 14 - 60 mm	ZAK 096	✓

KERNEBOR HKK RAIL

KORT**HM STANDARD**

HKK Rail HM Kernebor 17 - 36 mm med 19 mm Weldon skaft.
Velegnet til jernbaneskiner.
Skæredybde 30 mm.

Ø/mm	Varenr.	Lager
17	HKK-R 017	÷
18	HKK-R 018	÷
19	HKK-R 019	÷
20	HKK-R 020	÷
21	HKK-R 021	÷
22	HKK-R 022	÷
23	HKK-R 023	÷
24	HKK-R 024	÷
25	HKK-R 025	÷
26	HKK-R 026	÷

Ø/mm	Varenr.	Lager
27	HKK-R 027	÷
28	HKK-R 028	÷
29	HKK-R 029	÷
30	HKK-R 030	÷
31	HKK-R 031	÷
32	HKK-R 032	÷
33	HKK-R 033	÷
34	HKK-R 034	÷
35	HKK-R 035	÷
36	HKK-R 036	÷

CENTRERSTIFT ZAK 075



Størrelse	Varenr.	Lager
Ø 12 - 60 mm	ZAK 075	✓

SPÅNBRYDERTAP GWB



Snittap med spånbrøder HSS form B M8 - M20 mm med 19 mm Weldon skaft.

Ø	Varenr.	Længde/mm	DIN Form B	Lager
M8	GWB 008	90	371	✓
M10	GWB 010	100	376	✓
M12	GWB 012	110	376	✓
M16	GWB 016	110	376	✓
M18	GWB 018	125	376	✓
M20	GWB 020	140	376	✓

ADAPTER MK/WELDON



Beskrivelse	Varenr.	Lager
KEYLESS adapter med indvendig smøring. MK 2 med 19 mm Weldon skaft.	ZSS 200	✓
KEYLESS adapter med indvendig smøring. MK 3 med 19 mm Weldon skaft.	ZSS 300	✓
Adapter til manuel smøring. MK 2 med 19 mm Weldon skaft.	ZIA 219M	✓
Adapter til manuel smøring. MK 3 med 19 mm Weldon skaft.	ZIA 319M	✓
Adapter til manuel smøring. MK 4 med 19 mm Weldon skaft.	ZIA 419M	✓
Adapter til manuel smøring. MK 3 med 32 mm Weldon skaft.	ZIA 332M	✓
Adapter til manuel smøring. MK 4 med 32 mm Weldon skaft.	ZIA 432M	✓
Adapter med indvendig smøring. MK 2 med 19 mm Weldon skaft.	ZIA 219-KN	✓
Adapter med indvendig smøring. MK 3 med 19 mm Weldon skaft.	ZIA 319-KN	✓
Adapter med indvendig smøring. MK 3 med 32 mm Weldon skaft.	ZIA 332-KN	✓
Adapter med indvendig smøring. MK 4 med 19 mm Weldon skaft.	ZIA 419-KN	✓
Adapter med indvendig smøring. MK 4 med 32 mm Weldon skaft.	ZIA 432-KN	✓

GEVINDHOLDER/-ADAPTER

QUICK CHANGE SYSTEM



Beskrivelse	Varenr.	Lager
Quick change system Størrelse 2 Holder MK 2 Gevind M 5 - M 16	GSW 222	÷
Quick change system Størrelse 1 Holder MK 3 Gevind M 3 - M 14	GSW 331	÷
Quick change system Størrelse 2 Holder MK 3 Gevind M 5 - M 24	GSW 332	÷
Quick change system Størrelse 3 Holder MK 3 Gevind M 12 - M 30	GSW 333	÷
Quick change system Størrelse 2 Holder MK 4 Gevind M 5 - M 24	GSW 442	÷
Quick change system Størrelse 3 Holder MK 4 Gevind M 12 - M 30	GSW 443	÷
Quick change system Størrelse 4 Holder MK 4 Gevind M 20 - M 42	GSW 444	÷
Quick change indsats til gevindtappe Størrelse 1		
Gevind	Skaft Ø	Firkant
M3	3,5	2,7
M4	4,5	3,4
M5/M6	6,0	4,9
M8	8,0	6,3
M10	10	8,0
M12	9,0	7,0
M14	11,0	9,0
	GSE 103	÷
	GSE 104	÷
	GSE 105	÷
	GSE 108	÷
	GSE 110	÷
	GSE 112	÷
	GSE 114	÷

GEVINDADAPTER QUICK CHANGE SYSTEM



Beskrivelse			Varenr.	Lager
Quick change indsats til gevindtappe Størrelse 2				
Gevind	Skaft Ø	Firkant		
M5/M6	6	4,9	GSE 205	÷
M8	8	6,3	GSE 208	÷
M10	10	8,0	GSE 210.1	÷
M12	9	7,0	GSE 212	÷
M14	11	9,0	GSE 214	÷
M16	12	9,0	GSE 216	÷
M18	14	11,0	GSE 218	÷
M20	16	12,0	GSE 220	÷
M22/M24	18	14,5	GSE 222	÷
Quick change indsats til gevindtappe Størrelse 3				
Gevind	Skaft Ø	Firkant		
M14	11	9,0	GSE 314	÷
M16	12	9,0	GSE 316	÷
M18	14	11,0	GSE 318	÷
M20	16	12,0	GSE 320	÷
M22/M24	18	14,5	GSE 322	÷
M27	20	16,0	GSE 327	÷
M30	22	18,0	GSE 330	÷



GEVINDADAPTER M/SIKKERHEDSKOBLING QUICK CHANGE SYSTEM



Beskrivelse			Varenr.	Lager
Quick change indsats til gevindtappe Størrelse 2				
Gevind	Skaft Ø	Firkant		
M5/M6	6	4,9	GSS 205	÷
M8	8	6,2	GSS 208	÷
M10	10	8,0	GSS 210	÷
M12	9	7,0	GSS 212	÷
M16	12	9,0	GSS 216	÷
M18	14	11,0	GSS 218	÷
M20	16	12,0	GSS 220	÷
M22/M24	18	14,5	GSS 222	÷

GEVINDADAPTER M/SIKKERHEDSKOBLING

QUICK CHANGE SYSTEM



Beskrivelse				Varenr.	Lager
Quick change indsats til gevindtappe Størrelse 3					
Gevind	Skaft Ø	Firkant			
M12	9	7,0	GSS 312	÷	
M14	11	9,0	GSS 314	÷	
M16	12	9,0	GSS 316	÷	
M18	14	11,0	GSS 318	÷	
M20	16	12,0	GSS 320	÷	
M22/24	18	14,5	GSS 322	÷	
M27	20	16,0	GSS 327	÷	
M30	22	18,0	GSS 330	÷	
Quick change indsats til gevindtappe Størrelse 4					
Gevind	Skaft Ø	Firkant			
M20	16	12,0	GSS 420	÷	
M22/24	18	14,5	GSS 422	÷	
M27	20	16,0	GSS 427	÷	
M30	22	18,0	GSS 430	÷	
M33	25	20,0	GSS 433	÷	
M36	28	22,0	GSS 436	÷	
M39/42	32	24,0	GSS 442	÷	

WELDON TAPHOLDER

MELLEMSTYKKE



Beskrivelse				Varenr.	Lager
Mellemstykke med Weldon skaft					
Gevind DIN 376	Skaft Ø	Størrelse	Firkant		
M10	7	19 mm	5,5	ZGA 010	✓
M12	9	19 mm	7,0	ZGA 012	✓
M14	11	19 mm	9,0	ZGA 014	✓
M16	12	19 mm	9,0	ZGA 016	✓
M18	14	19 mm	11,0	ZGA 018	✓
M20	16	19 mm	12,0	ZGA 020	✓
M22/24	18	32 mm	14,5	ZGA 022	✓
M27	20	32 mm	16,0	ZGA 027	✓
M30	22	32 mm	18,00	ZGA 030	✓

THREAD CUTTING SYSTEMS

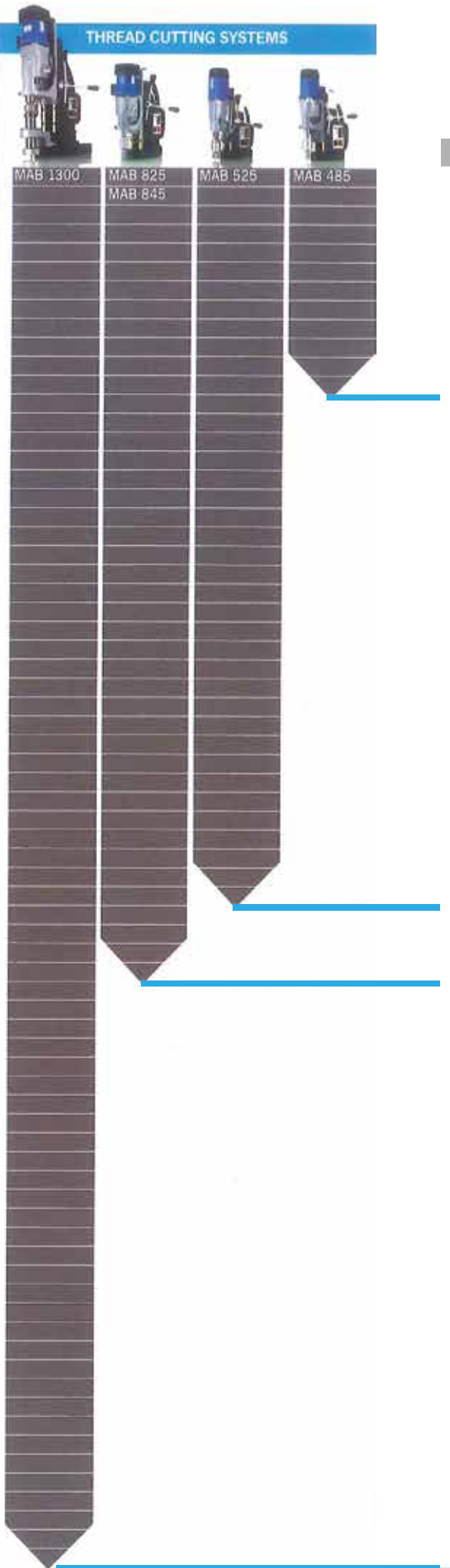

GSW













GSE



GSS

Hurtigskiftesystem	Gevind	GSE Varenr.	GSS Varenr.	
GSW 222 Størrelse 2 MK 2	M5/M6	GSE 205	GSS 205	
	M6		GSS 206	
	M8	GSE 208	GSS 208	
	M8		GSS 205	
	M10	GSE 210-DIN 371		
	M10	GSE 210	GSS 210	
	M12	GSE 212	GSS 212	
	M14	GSE 214	GSS 214	
GSW 331 Størrelse 1 MK 3	M4	GSE 104		
	M5/M6	GSE 105		
	M8	GSE 108		
	M10	GSE 110		
	M12	GSE 112		
	M14	GSE 114		
	GSW 332 Størrelse 2 MK 3	M5/M6	GSE 205	GSS 205
		M6		GSS206
M8		GSE 208	GSS 208	
M8			GSS 205	
M10		GSE 210.1		
M10		GSE 210	GSS 210	
M12		GSE 212	GSS 212	
M14		GSE 214	GSS 214	
M16		GSE 216	GSS 216	
M18		GSE 218	GSS 218	
M20		GSE 220	GSS 220	
ikke egenet til MAB525		M22/M24	GSE 222	GSS 222
GSW 333 Størrelse 3 MK 3		M12		GSS 312
		M14	GSE 314	GSS 314
	M16	GSE 316	GSS 316	
	M18	GSE 318	GSS 318	
	M20	GSE 320	GSS 320	
	GSW 333 Størrelse 3 MK 3	M22/M24	GSE 322	GSS 322
M27		GSE 327	GSS 327	
M30		GSE 330	GSS 330	
GSW 442 Størrelse 2 MK 4	M5/M6	GSE 205	GSS 205	
	M6		GSS 206	
	M8	GSE 208	GSS 208	
	M8		GSS205	
	M10	GSE 210-DIN 371		
	M10	GSE 210	GSS 210	
	M12	GSE 212	GSS 212	
	M14	GSE214	GSS214	
	M16	GSE 216	GSS 216	
	M18	GSE 218	GSS 218	
	M20	GSE 220	GSS 220	
	M22/24	GSE222	GSS 222	
	GSW 443 Størrelse 3 MK 4	M12		GSS 312
		M14	GSE 314	GSS 314
M16		GSE 316	GSS 316	
M18		GSE 318	GSS 318	
M20		GSE 320	GSS 320	
M22/24		GSE 322	GSS 322	
M27		GSE 327	GSS 327	
M30		GSE 330	GSS 330	
GSW 444 Størrelse 4 MK 4		M20		GSS 420
		M22/24		GSS 422
	M27		GSS 427	
	M30		GSS 430	
	M33		GSS 433	
	M36		GSS 436	
	M39/42		GSS 442	

TILBEHØR ADAPTER

	Beskrivelse	Varenr.	Lager
	Adapter fra 32 mm Weldonskaft til 19 mm Weldonskaft	ZAP 200	✓
	Adapter fra 32 mm Weldonskaft til 19 mm Weldonskaft ADVARSEL: Brug af denne adapter kan medføre overbelastning af maskinen!	ACRW32	✓
	Adapter med Weldonskaft 19mm bruges til FEIN kernebor. Gevind M18 X 6 P1,5t	ZAF 002	÷
	Adapter med Weldonskaft 19mm til FEIN kernebor med QuickIN skaft	ZAF 003	✓
	Adapter med QuickIN skaft til Weldonskaft 19mm	ZAF 004	✓
	Adapter med NITTO One Thoch skaft til Kernebor med Weldonskaft	ZAF 005	✓
	107 mm centererstift til adapter ZAF 004 og ZAF 005	ZAK 107	✓
	Borepatron adapter Weldonskaft 19 mm 1/2" x 20 UNF	ZAP 100	✓
	Weldonskaft forlænger 80 mm Weldonskaft 19 mm	ZAP 300	✓
	HSS-forsænker 90° med 3 skær, 19 mm Weldonskaft, Ø 10 - 40 mm	ZSE 040	✓
	HSS-forsænker 90° med 3 skær, 19 mm Weldonskaft, Ø 15 - 50 mm	ZSE 050	✓
	Sikkerhedskæde til magnetboremaskine	ZSK 001	✓

KANTFRÆSER

SKF 025



Optagen effekt (KW)	1.100
Volt	220-240
Omdrejningstal (o/min)	2.850
Fræserbredde (mm)	15
Håndføring	✓
Trinløs vinkel indstilling	15-60°
Sikkerhed	Automatisk sluk ved overbelastning
Vægt (kg)	22,0
Kantfræser (2 rækker) med 10 HM-platte	✓
Varenr.	SKF 025
Lager	÷

TILBEHØR

KANTFRÆSER



Tilbehør til SKF 025	Varenr.	Lager
HM-platte	SHM 800	÷
Kantfræser uden HM platter	ZFR 250	÷

KANTFRÆSER

EKF SERIEN



Motor effekt (Watt)	1.500
Volt	220-240
Omdrejningstal (o/min)	6.000
Vinkel (grader) og fræserbredde (mm)	30° 0-5
Vinkel (grader) og fræserbredde (mm)	45° 0-6
Radius (mm)	R 2,5
Vægt (kg)	4,6
Varenr.	EKF 300.3 45° R 2,5 EKF 450.3 EKF 452.3
Lager	✓

KANTFRÆSER

EKF 530/545



EKF Serien	530	545
Motor effekt (Watt)	1.800	1.800
Volt	230	230
Omdrejningstal (o/min) Elektronisk hastighedsregulering med fuld styreelektronik	1.850-3.350	1.850-3.350
Vinkel (° grader)	30°	45°
Fræserbredde (mm)	0-12	0-12
Fræserhoved	ZFR 530	ZFR 545
Fræsertype	SHM 900 og SHM 900 E	SHM 900 og SHM 900 E
Fremføring	Manuel	Manuel
Størrelse (HxBxL) i mm	300 x 350 x 375	300 x 350 x 375
Vægt (kg)	9,3	9,3
Varenr.	EKF 530	EKF 545
Lager	÷	÷

KANTFRÆSER





EKF 630/645



EKF Serien	630	645
Motor effekt (Watt)	2.300	2.300
Volt	230	230
Omdrejningstal (o/min) Elektronisk hastighedsregulering med fuld styreelektronik	1.600-3.000	1.600-3.000
Vinkel (° grader)	30°	45°
Fræserbredde (mm)	0-15	0-15
Fræserhoved	ZFR 630	ZFR 645
Fræsertype	SHM 900 og SHM 900 E	
Fremføring	Manuel	Manuel
Størrelse (HxBxL) i mm	300 x 350 x 400	300 x 350 x 400
Vægt (kg)	10,2	10,2
Varenr.	EKF 630	EKF 645
Lager	÷	÷

TILBEHØR

KANTFRÆSER/EKF SERIEN

	Beskrivelse	Varenr.	Lager
	Fræse værktøj til 30° EKF 300.3 (3 platter)	ZFR 300.3	✓
	Fræse værktøj til 45° EKF 450.3 (3 platter)	ZFR 450.3	✓
	Fræse værktøj til R 2,5 EKF 452.3 (3 platter)	ZFR 452.3	✓
	HM-platte til 30° og 45°	SHM 200	✓
	HM-platte - Vario belagt til 30° og 45°	SHM200-E	✓
	HM-platte til R 2,5 mm	SHM 202	✓
	Stativ til kantfræsning af små emner	ZKF 100	÷
	Fræse værktøj til 30° EKF Serie 500	ZFR 530	÷
	Fræse værktøj til 45° EKF Serie 500	ZFR 545	÷
	Fræse værktøj til 30° EKF Serie 600	ZFR 630	÷
	Fræse værktøj til 45° EKF Serie 600	ZFR 645	÷
	HM-platte til 30° og 45° EKF serie 500/600	SHM 900	÷
	HM-platte til 30° og 45° EKF serie 500/600	SHM 900 E	÷

TEKNISKE TEGNINGER



MAB 485

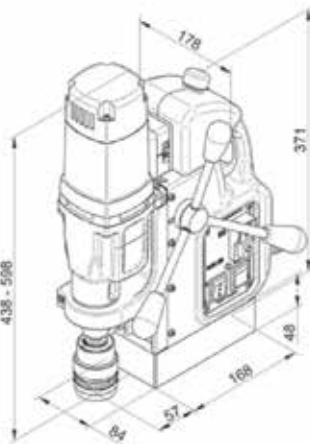

MAB 525

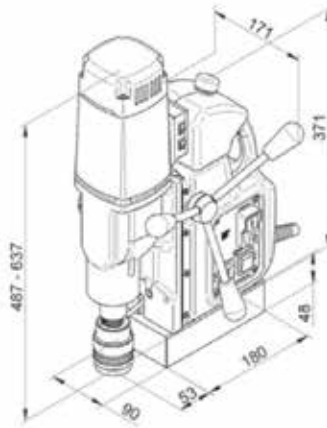

MAB 825

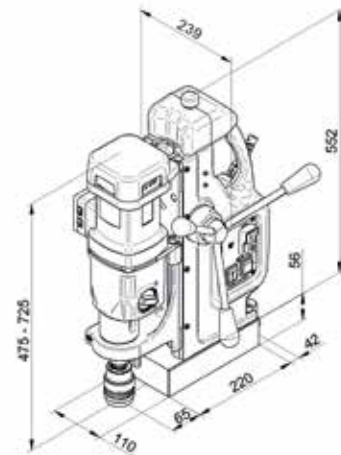

MAB 845

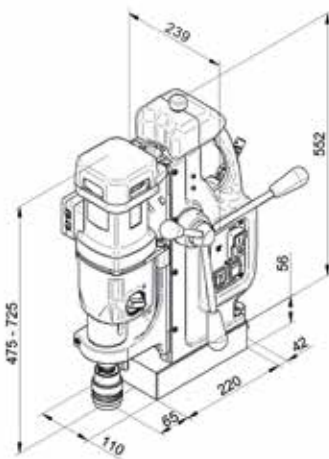

MAB 1300

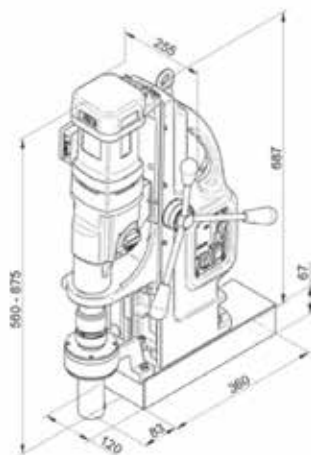

MAB 100K

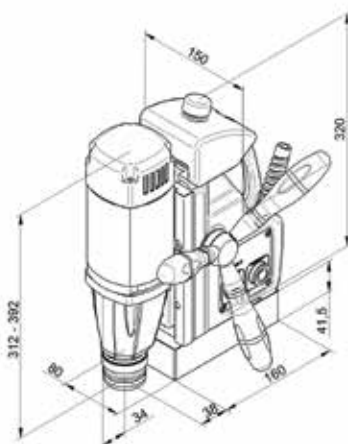

MAB 455

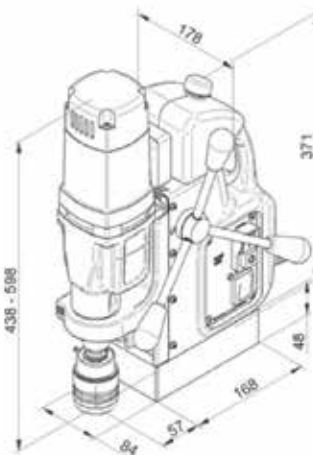

TEKNISKE TEGNINGER



MABasic 400

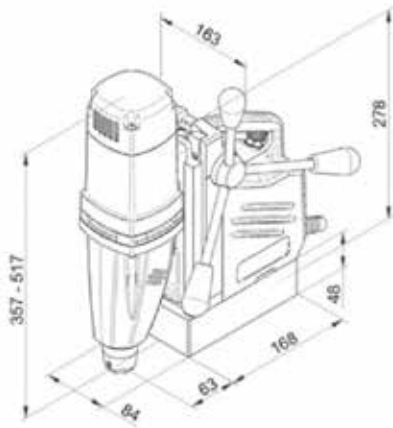

MABasic 450

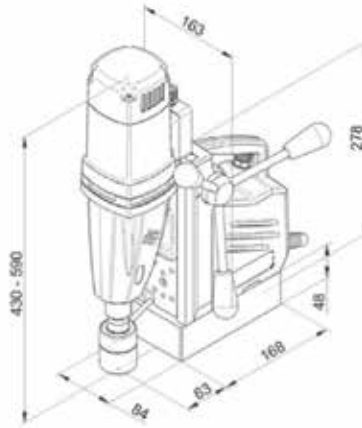

MABasic 850

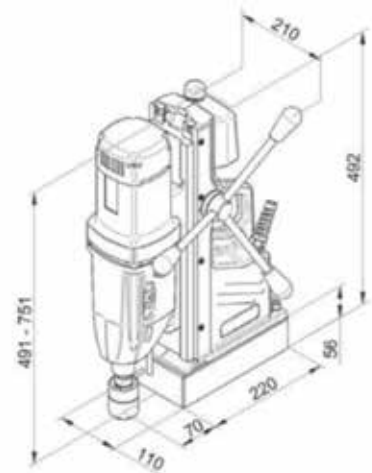

MAB 155PRO

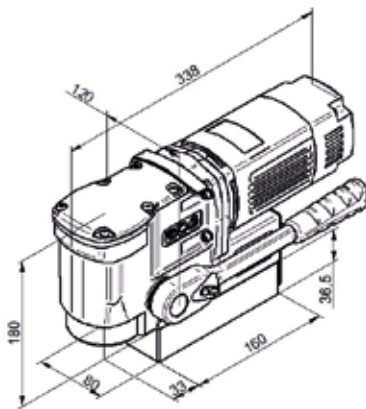

MAB 825 V/845 V

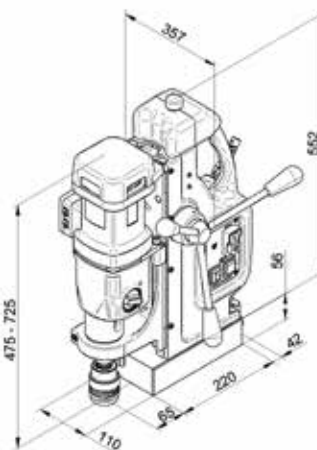

MAB 1300V

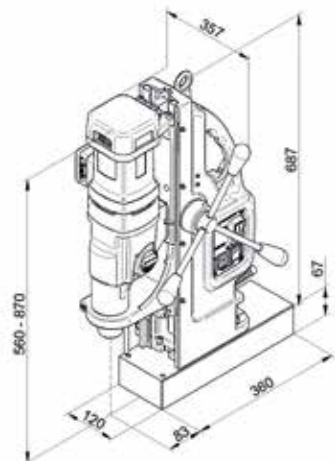

AutoMAB 350

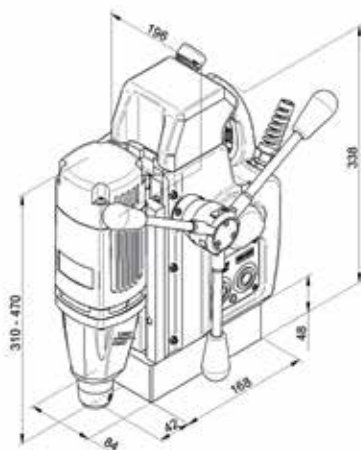

AutoMAB 450

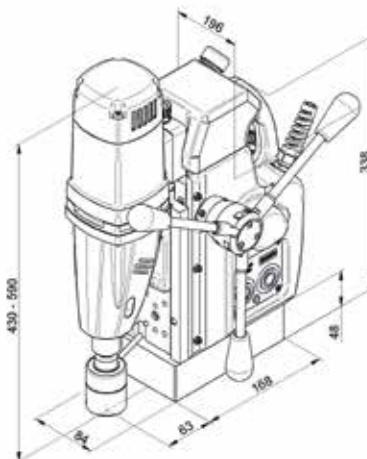

AirMAB 5000PRO

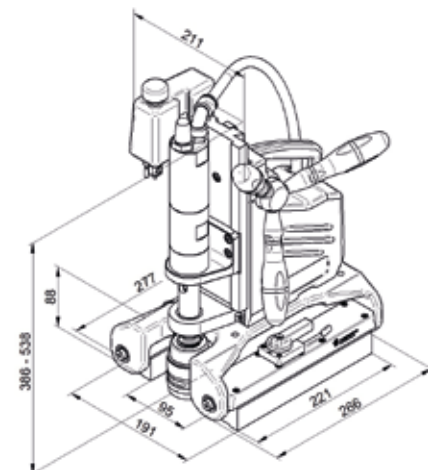



PipeMAB 200

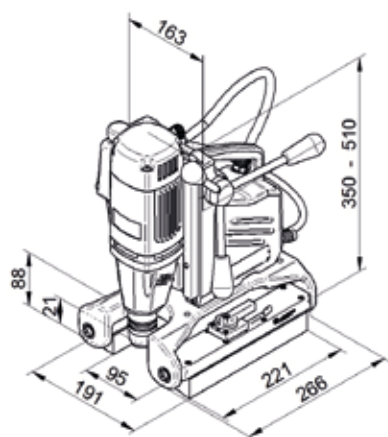

PipeMAB 525

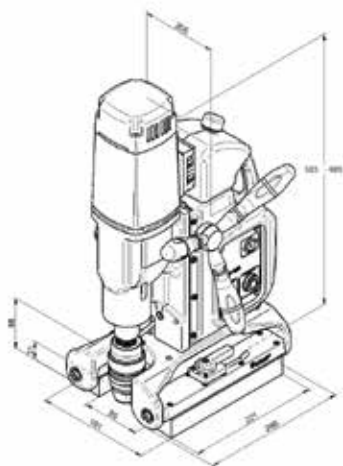

RailMAB 915

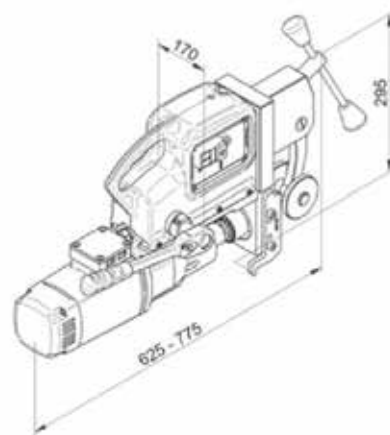

RailMAB 965

